

Kawahara's SCISSORS LIFTER



Platform Size up to 20m
Lifting Capacity up to 50Ton

We can design your size and capacity.
And quick delivery based on standard parts and calculation.

Model : KW-1224-30-1

Specification

Model : KW-1224-30-1
Platform Size : 2400 x 1200 (mm)
Lift Stroke : 3000 (mm)
Max. Height : 3600 (mm)
Min. Height : 600 (mm)
Capacity : 1000 (kg)
Lifting Time : About 70 (sec)
Lowering Time : Adjustable
Cylinder Size : Dia.60 x 800st (mm) x 2pcs
Pump : 140 (kg/cm²) 11.9 (l/min)
Power : 3ph AC415V 50Hz
Motor : 2.2kw 4P
Control : Push Button
Color : Orange
Machine Weight : About 1000 (kg)

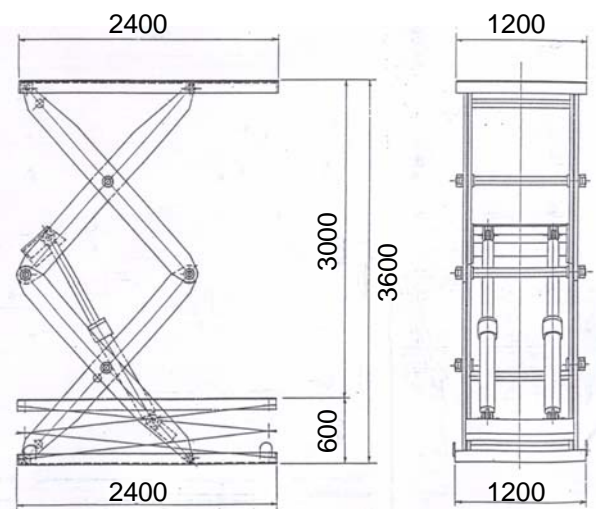

KAWAHARA
ENGINEERING WORKS SDN BHD
(Co. No. 412286-P)

Material Handling System & Factory Automation

KAWAHARA ENGINEERING WORKS SDN BHD

No.3, Jalan SC2, Pusat Perindustrian Sg. Chua,
43000 Kajang, Selangor Darul Ehsan, Malaysia

Tel : 603-8739-9672 Fax : 603-8739-9673

E-mail : kewsb@pd.jaring.my